

SEPARATING DEVICE FOR CAPTURING FINE PARTICLES FORMED DURING OPERATION OF FLUIDIZED BED REACTORS

V. E. Zinurov,¹ A. V. Dmitriev,¹ A. A. Abdullina,¹ E. I. Salakhova,²
and O. S. Dmitrieva²

UDC 66.074.2

During operation of fluidized bed reactors, problems associated with capture of catalyst dust particles from the exhaust gases are encountered. A design of the separating device having arcuate components is proposed for their solution. It is shown that the ascending gas flow significantly reduces particle capture efficiency because of repeated entrainment of the separated particles. Three types of separation grids were considered for degrading the descending and ascending gas flows. It was found that it is necessary to use separation grids not only for effective channeling of trapped particles into the device bin without formation of “dead” zones, but also for generating resistance to movement of the ascending gas flow. Most effective is the grid made of longitudinal and cross *V*-shaped plates. The optimum gas velocity in the inlet of separating device having arcuate components is 1 m/sec, which ensures minimum abrasion wear of the structural components of the separating device in the operation process. The particle capture efficiency is 88.6% and hydraulic resistance is 43.9 Pa.

Keywords: separating device, particle capture, fluidized bed, catalyst dust, separation grid, capture efficiency.

Fluidized bed reactors used widely in chemical industry (for example, for heterogeneous catalytic reactions) are characterized by high phase contact intensity and high heat exchange efficiency. However, due to intense movement and mixing of the fluidized bed, catalyst particles are submitted to high mechanical stresses because of collisions between the particles and with the apparatus wall [1].

The abrasion process depends on many factors (properties of the particles, fluidization conditions, structure of the fluidized bed, etc.) [2, 3], so the hydrodynamics of the bed changes with time [4, 5].

The main consequence of abrasion of fluidized bed particles is formation of finely divided particles entrained from the reactor by the gas flow, which reduces the catalyst reserve and the reactor operation efficiency. Replacement of the abraded catalyst is one of the major operating costs [6]. Also, entrainment of the formed dusts by the outgoing gases affects the operation of the successive units: efficiency of their operation decreases, erosion wear of the equipment mechanisms increases, processes of corrosion of metals intensifies, dust entrainment increases air pollution and, in certain concentrations, affects health of people.

Dust catchers, among which the most popular are cyclones, prevent catalyst loss with emissions of exhaust gases to the atmosphere and return catalyst to the fluidized bed [7]. In most cases, the size of catalyst particles in the fluidized bed ranges from 10 to 100 μm initially [8], but considerable amounts of particles with sizes $<20 \mu\text{m}$ are lost from the cyclones. The low effectiveness of separation of fine particles in cyclones is explained by the fact that the hydrodynamic resistance force in this case is much greater than centrifugal force [9]. Because of this, studies and development of new dust-catching devices are important for enhancing efficiency of cleaning gases from fine catalyst particles.

¹ Kazan State Power Engineering University, Kazan, Russia.

² Kazan National Research Technological University, Kazan, Russia; e-mail: ja_deva@mail.ru.

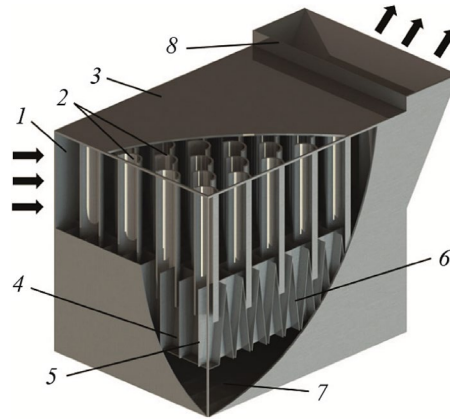

Fig. 1. Three-dimensional model of separating device with arcuate components (view with local section): 1 — inlet pipe; 2 — arcuate components; 3 — housing; 4 — separation grid; 5 — longitudinal plates; 6 — cross V-shaped plates; 7 — bin; 8 — outlet pipe.

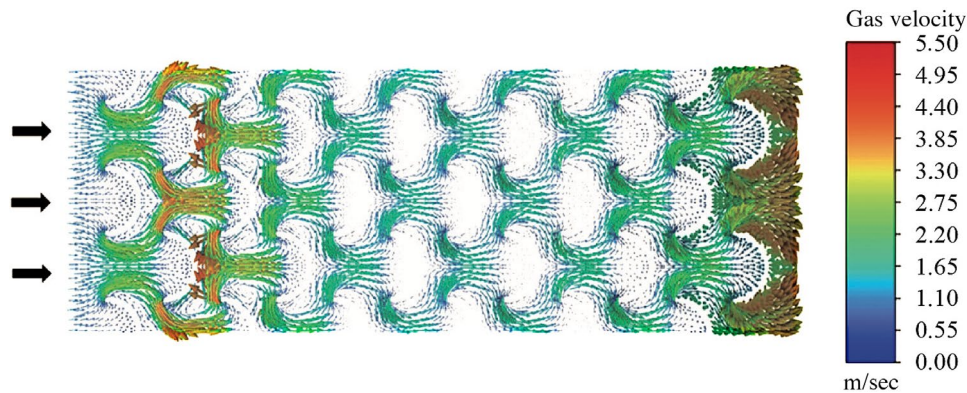

Fig. 2. Schematic diagram of gas flow structure (at entry rate of 1 m/sec) in separating device having arcuate component under symmetry condition (longitudinal section).

For catching fine particles from gas streams, a separating device with arcuate components is proposed (Fig. 1). The main units of the structure are arcuate components 2 placed in the housing 3 and inset into the separation grid 4.

In previous studies [10, 11] it was found that the hydraulic resistance of this device is less than the hydraulic resistance of cyclone separator.

Principle of Operation of the Proposed Separating Device. The dust-laden gas stream, when fed into the device (through the inlet pipe 1) strikes the arcuate components 2 located in the separating device in checkered order [12, 13], due to which a wavy gas flow structure is formed (Fig. 2).

The diameter of the arcuate components is relatively small, so the gas turning radius is also small (because these two parameters are equal). As a result, the centrifugal forces acting on the solid particles in the flow are high when the dust-laden gas moves. Another important force acting on the particles is gravitational force. Thus, under the action of these forces the particles are “forced out” of the flow when the flow lines twist and shift toward the arcuate components 2 (Fig. 1) and the particles rebound and fall into the stagnant zones with near-zero gas flow velocities (inside the arcuate components and immediately after them, Fig. 2) upon contact with the surface of the components 2. The particles settle in the separator bin 7 gradually (Fig. 1). After contact with the arcuate components 2, a relatively small fraction of the particles rebounds to the moving wavy gas flow

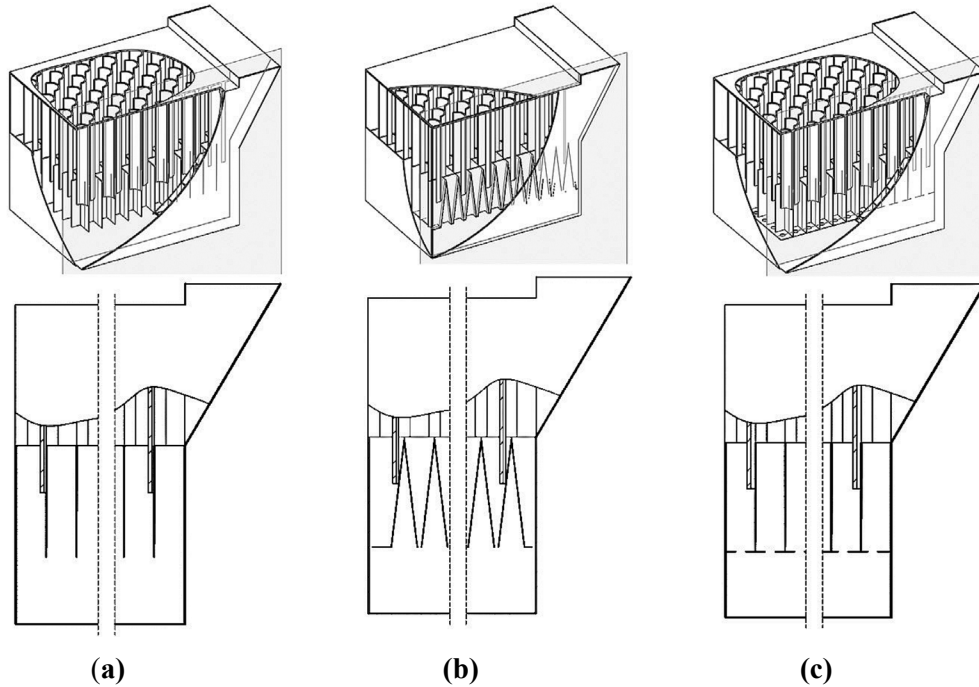

Fig. 3. Schematic diagram of separation grids (longitudinal section): (a) — honeycomb grid made of longitudinal and cross plates; (b) — of longitudinal and V -shaped plates; (c) — of longitudinal and V -shaped plates with perforated bottom.

and is carried away by the flow in the direction of the next rows of arcuate components 2, whereupon the probability of entrainment of particles from the separator diminishes. The cleaned gas comes out through the outlet pipe 8. The separation grid 4 in the bottom section of the separators is provided for degrading the ascending “parasite” gas stream formed when the gas flows around the arcuate components 2 from the bottom upward. Some of the particles entering the space under the arcuate components are carried away by gas streams “slipping” from the bottom. These streams decrease significantly when V -shaped plates are installed, whereupon the separation efficiency of the device increases. Separation grid 4 consists of longitudinal plates 5 and cross V -shaped plates 6 (Fig. 1) relative to the gas stream direction, longitudinal plates 5 acting as stiffening ribs.

All the arcuate components 2 inserted into the plates 5 to a fixed depth, which prevents shakiness of the plates during separator operation. The V -shaped plates 6 are so installed relative to each other that small slots (up to 10 mm in size) intended for particle delivery to the bin are formed in the lower part of plates (Fig. 1). Formation of small slots is necessary also for degrading the ascending gas stream. Small straight plates directed toward the inner wall of the separator housing are welded in the lower part of the first and last V -shaped plates to prevent formation of the descending and ascending gas flows, respectively.

In this case, between housing 3 and the plate directed to the V -shaped plate 6 there is a slot (up to 10 mm in width) perpendicular to the gas flow direction for preventing “dead” zones where particles may accumulate (Fig. 3b).

The distance between the rows of arcuate components l [m] is determined by the equation $l = \sqrt{0.75d_{m,1}}$ (where $d_{m,1}$ — diameter of the line passing through the middle of the wall of the arcuate components, m), which was obtained by theoretical calculations.

It was shown earlier [12] that separator efficiency diminishes because of “parasite” flows, which leads to return of particles back to the structured gas stream after separation of particles. One of the effective solutions for eliminating parasite ascending flows is application of separation grids.

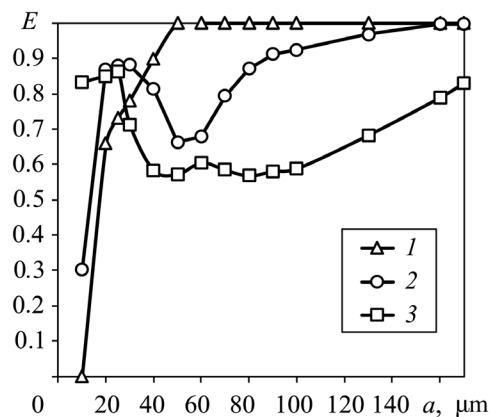

Fig. 4. Dependence of solid particles capture efficiency of separating device having honeycomb grid and arcuate components on particle diameter and gas velocity at inlet (bottom section of grid covered by plate with particle adhesion condition): 1 — $W = 1$ m/sec; 2 — $W = 3$ m/sec; 3 — $W = 7$ m/sec.

The goal of this work was to study the influence of the design of the separation grid of the device having arcuate components on the solid particle catching efficiency.

Three main types of separation grids were investigated: honeycomb grid made of longitudinal and cross plates (Fig. 3a), of longitudinal and cross V -shaped plates (Fig. 3b), and of longitudinal and cross plates with continuous perforated bottom (Fig. 3c).

In Fig. 3, the local section of various separation grids is made at a specified depth, at which longitudinal plates are not visible because in all the proposed designs the longitudinal plates are similar and they act as strengthening ribs.

Several three-dimensional models of separator having different grids were constructed for studies by the method of numerical model using Ansys Fluent.

The key dimensions of the three-dimensional model of separating devices having arcuate components are: diameter of the middle line of the arcuate components $d_{m,1} = 52.5$ mm; thickness of the components — 4.5 mm; thickness of the plates of the separation grid — 2 mm; number of rows of arcuate components — 12.

The separation efficiency of the device was calculated by the equation $E = 1 - G_{out}/G_{in}$ (where G_{out} , G_{in} — mass particle flow rates at the device outlet and inlet, g/sec).

During the studies, we varied the gas flow rate W at the separator inlet (from 1 to 7 m/sec), particle size a (from 10 to 170 μm), and particle flow rate G_{in} (from 3.3 to 39.3 g/sec). The particle density ρ_a during the studies was taken as 3400 kg/m³. It was determined earlier [11] that in iso-paraffin dehydrogenation processes (using Al–Cr catalyst) the size of more than 98% of particles in the fluidized bed ranges from 25 to 100 μm .

In case of numerical modeling, in order to simplify, the symmetry condition was adopted because along the device width the geometry of the arcuate components and of the separation grids does not change.

Note that while determining the optimum gas flow velocity at the inlet (Fig. 4) the return flows from the separation grid side was ignored, i.e., in the model the bottom section of the grid was covered by the plate and the condition of particle adhesion was assigned to it (assuming that the return “parasite” flows that affect particle entrainment will be eliminated).

From the modeling results (Figs. 4 and 5) it was concluded that technological parameters and design of separation grid significantly affect the process of solid particle capture in a separating device with arcuate components.

While varying the dust-laden gas flow velocity at the device inlet (1–7 m/sec) it was found that the optimum velocity is 1 m/sec because it ensures high particle catching efficiency (86.2% on average). With increase

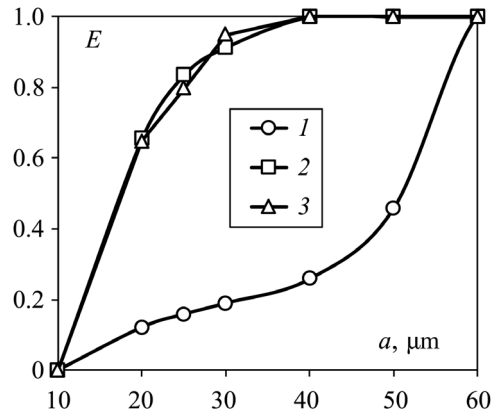

Fig. 5. Dependence of efficiency of solid particle capture by separating device having arcuate components on particle diameter a . Grid design: 1 — honeycomb from longitudinal and cross plates; 2 — from longitudinal and cross V -shaped plates; 3 — from longitudinal and cross plates with perforated bottom.

of the dust-laden gas flow velocity at the device inlet the capture efficiency decreases (average for 10–170 μm particles) because the centrifugal force acting on the particles in the gas flow intensifies, i.e., the particles are knocked out with great force from the flow structure (particle pulse in this case is high). As a result, the particle hit the wall of the arcuate components and bounce back to the moving dusty gas flow, i.e., the particles do not fall into the stagnant zones with near-zero velocities (inside the arcuate components and immediately after them) and fail to settle in the bin.

From the data in Fig. 4 it follows that the higher the velocity of the dust-laden gas flow, the lower the efficiency of capture of particles larger than 30 μm . High dusty gas flow velocity at the device inlet provides the possibility of catching finely dispersed particles (size less than 20 μm) with a high efficiency. However, the dispersity of the major fraction of the particles in the studied gas flow is 25–100 μm , so it is advisable to adjust the velocity of gas -laden gas supply into the separating device, taking account of the characteristics of the dust and the particle size. On the other hand, low flow entry velocity may ensure low hydraulic resistance of the separating device and low intensity of abrasion wear of arcuate components.

The efficiencies of separating device having arcuate components are, on average, 86.2, 82.5, and 68.9% at inlet dust-laden gas velocities of 1, 3, and 7 m/sec, respectively.

Note that observation of minimums on the efficiency curve (Fig. 4) is generally interpreted as an indication of agglomeration of particles, but presence of agglomeration in the device does not guarantee presence of minimums on the curve.

From the separating grid design point, grid made of longitudinal and cross V -shaped plates (Fig. 3b) is most efficient (average efficiency 88.6% (Fig. 5)).

On the one hand, the adjacent V -shaped plates (between vertices of which channels narrowed from the top down are formed) are guiding for channeling particle separated from the dust-laden gas flow into the device bin.

On the other hand, use of V -shaped plates precludes formation of “dead” zones, where particles may accumulate, which may lead to entrainment of particles from the device or clogging of the whole separating grid.

Furthermore, significant head resistance to movement of “parasite” ascending gas flow develops in the channels between the V -shaped plates.

Separating grid made of longitudinal and cross plates with perforated bottom (Fig. 3c) also ensures high efficiency of the separating device (average 88.5%, Fig. 5).

A large part of the flow passage in the lower section of the separating grid is closed by the bottom with holes, so formation of descending flow is ruled out.

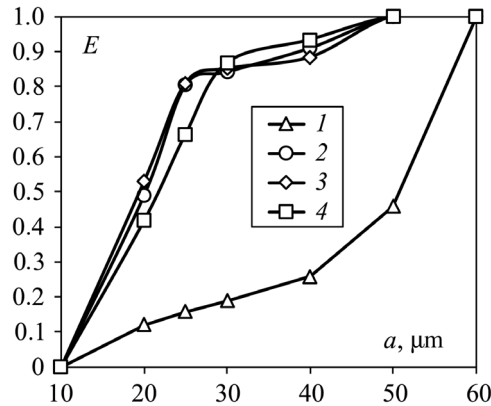

Fig. 6. Dependence of solid particle capture efficiency of separating device having arcuate components and honeycomb grid on particle diameter a with covering of specific rows of square outlet cells: 1 — all cells open (Fig. 3a); 2 — first and twelfth rows covered; 3 — first, eleventh, and twelfth rows covered; 4 — first, second, eleventh, and twelfth rows covered.

Holes with a small diameter in the separating grid bottom (Fig. 3c) ensure the same key function as the channels between the adjacent V -shaped plates (Fig. 3b), i.e., a part of the section for passage of the gas bearing the particles for degradation of “parasite” ascending flow is covered, but a demerit of the separating grid made of longitudinal and cross plates having a perforated bottom is formation of a multitude of “dead” zones (for example, at the junctions of the arcuate components and the surface of the bottom without holes) where (with a high probability) particles may accumulate. The efficiency of the separating device is the minimum (65.6% on average, Fig. 5) when honeycomb separating grid is used (Fig. 3a). The separating grid is open at the bottom, so there is no hindrance to formation of descending gas flow in the region of the first rows of arcuate components and of ascending gas flow in the region of the last rows of arcuate components.

As the ascending gas flow circumvents the separating grid, separated particles are picked up and carried away from the bottom and fall into the bin.

A row of cells of the separating grid (the so-called honeycomb), through which both descending and ascending flow may pass, corresponds to each of the 12 rows of arcuate components in the device. During the study of the distribution of gas flows through these cells, the following was established: the main descending gas flow passes through the first, second, and third rows; the ascending gas flow is more prominent in the tenth, eleventh, and twelfth rows of cells; passage of descending and ascending gas flow is minimum through the 4th–9th rows of cells.

For degrading parasite descending and ascending flows in the lower part of the separating grids, some cavities were covered by straight plates welded to cross plates (like the plates welded to the first and last V -shaped plates of the grid in Fig. 3b). For this, slots up to 10 mm in size were provided to prevent clogging of the cavities by particles.

From the modeling results (Fig. 6) it was concluded that covering of the first, second, eleventh, and twelfth rows ensures degradation of the main descending and ascending flows, whereupon the efficiency of the device increases by 1.3 times.

It was also found that covering (as a minimum) of the first and twelfth rows is essential for a significant increase of efficiency.

The hydraulic resistance of a separating device having arcuate components at gas-laden flow entry velocity of 1 m/sec is 57.2 Pa when honeycomb separating grid made of longitudinal and cross plates are used, is 43.9 Pa when grid made of longitudinal and cross V -shaped plates are used, and 94.5 Pa when grid made of longitudinal and cross plates with a perforated bottom are used.

The efficiency of the separating device having arcuate components for capturing 25–100 μm particles is on average 67.3% when honeycomb separating grid made of longitudinal and cross plates are used, 97.2% when grid made of longitudinal and cross *V*-shaped plates are used, and 97.1% when grid made of longitudinal and transverse/cross plates with a perforated bottom are used (Fig. 5).

Depending on the covering of cells (Fig. 6), the efficiency of a separating device having arcuate components is on average 65.6% (all cells open), 86.1% (first and twelfth rows of cells closed), 86.2% (first, eleventh, and twelfth cells are closed), and 84.9% (first, second, eleventh and twelfth rows of cells closed).

Thus, parasite ascending gas flow in the bottom part of the separating device having arcuate components significantly affects the particle capture efficiency.

Installation of a separating grid in the housing of the device greatly levels out the parasite descending and ascending flows, which ensures considerable improvement of the device efficiency.

However, for this, it is necessary to select the separating grid design judiciously ensuring not only the efficiency of pouring of captured particles into the bin of the device (without formation of “dead” zones where particles may accumulate), but also to create resistance to the movement of the ascending gas flow.

CONCLUSIONS

A separating device having arcuate components (with different types of separating grid) has been developed for capturing fine particles from gas flows.

Based on the modeling results, the optimum gas flow velocity at the inlet of the separating device having arcuate components is 1 m/sec.

Entrainment of captured particles can be reduced and the efficiency of the device can be improved significantly by degrading the descending and ascending gas flows using separating grids in the bottom section of the device.

The most effective is separating grid from longitudinal and cross *V*-shaped plates. The efficiency of separating device with such grid is on average 88.6%.

The hydraulic resistance of the separating device with grid from longitudinal and cross *V*-shaped plates is 43.9 Pa.

The main advantages of separating device having arcuate components are high efficiency of particle capture at relatively low gas velocity, low hydraulic resistance, and long service life (due to weak abrasion wear of the structural components of the separator).

The study was conducted with the financial support of the stipend SP–3577.2002.1 from the President of the Russian Federation to young under-graduate and post-graduate students.

REFERENCES

1. H. L. Zhang, J. Degève, J. Baeyens, and S. Y. Wu, “Powder attrition in gas fluidized beds,” *Powder Technology*, **287**, 1–11 (2016).
2. D. Wu, Z. Gu, and Y. Li, “Attrition of catalyst particles in a laboratory-scale fluidized-bed reactor,” *Chemical Engineering Science*, **135**, 431–440 (2015).
3. L. Yang, C. Song, L. Ai, et al., “Collision characteristics and breakage evolution of particles in fluidizing processes,” *Fuel Processing Technology*, **243**, Article 107654 (2023).
4. F. Alobaid, N. Almohammed, M. M. Farid, et al., “Progress in CFD simulations of fluidized beds for chemical and energy process engineering,” *Progress in Energy and Combustion Science*, **91**, Article 100930 (2022).
5. J. Liao, L. Zhu, and Z. Luo, “Heterogeneity analysis of gas–solid flow hydrodynamics in a pilot-scale fluidized bed reactor,” *Chinese Journal of Chemical Engineering*, **50**, 117–129 (2022).

6. J. Werther and J. Reppenhagen, *Handbook of Fluidization and Fluid-Particle Systems*, Marcel Dekker, New York (2003), pp. 201–238.
7. Z. Reinking, K. J. Whitty, and J. A. S. Lighty, “Design of a gas-solid-solid separator to remove ash from circulating fluidized bed reactors,” *Powder Technology*, **404**, Article 117467 (2022).
8. N. A. Pakhomov, O. A. Parakhin, E. I. Nemykina, et al., “Development and experience of industrial use of KDM microspherical Al–Cr isobutane dehydrogenation catalyst,” *Kataliz v Prom.*, No. 3, 65–75 (2012).
9. D. I. Misyulya, V. V. Kuzmin, and V. A. Markov, “Comparative analysis of technical characteristics of cyclone dust catchers,” *Tr: BGTU, Khim. Tekhnol. Neorg. Veshchestv*, No. 3, 154–163 (2012).
10. E. I. Salakhova, A. V. Dmitriev, V. E. Zinurov, et al., “Dust collector for paraffin dehydrogenation units with a fluidized catalyst bed,” *Catalysis in Industry*, **14**, No. 4, 369–375 (2022).
11. E. I. Salakhova, V. E. Zinurov, A. V. Dmitriev, and I. I. Salakhov, “Modeling of erosion in a cyclone and a novel separator with arc-shaped elements,” *Processes*, **11**, No. 1, Article 156 (2023).
12. V. E. Zinurov, N. Z. Dubkova, O. S. Popkova, and O. S. Dmitrieva, “Efficiency of different separation elements for removal of fine particles from gas,” *Journal of Physics: Conference Series*, **1745**, Article 012090 (2020).
13. V. E. Zinurov, A. V. Dmitriev, and V. V. Kharkov, “Influence of process parameters on capturing efficiency of rectangular separator,” *IEEE International Conference on Information Technology and Nanotechnology* (2020), pp. 1–4.